



This page includes photographs of all the Cool-Air door systems including the "HB" Horizontal Bi-fold, "IS" Inside Slider, "BR" Bottom Rolling Doors, the New "FT" Fold-Tite Stacker and a combination of each of these door systems.



**Cool-Air, Inc.** © 2008 Cool-Air, Inc. Manufactured by:  
**Po Box 2280**  
**Malta, NY 12020**  
**Toll Free 866-580-8980 International 518-580-8980**  
**Fax 518-691-8347** sales@ManualHangarDoors.com



## CSA-4.5-AC Accordion Folding Door System From Cool-Air

*Balanced Design  
 With an equal amount  
 of the open door setting  
 inside and outside the  
 the building.*

*Easy operation yet  
 Strong - Wind resistant*

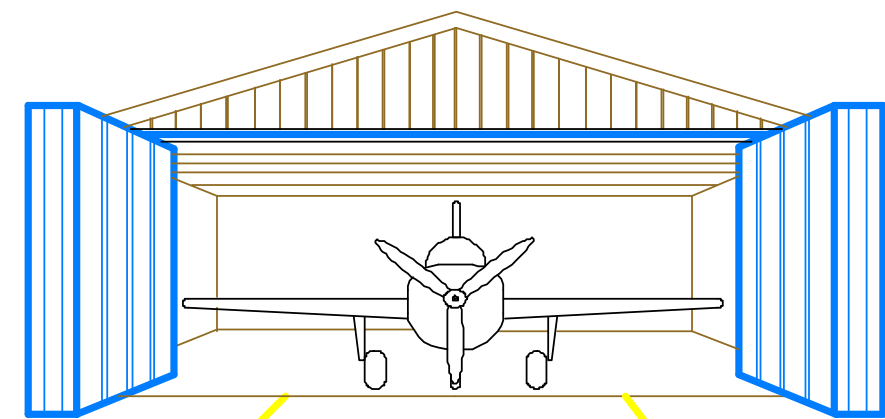
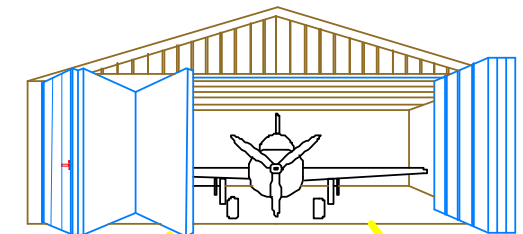
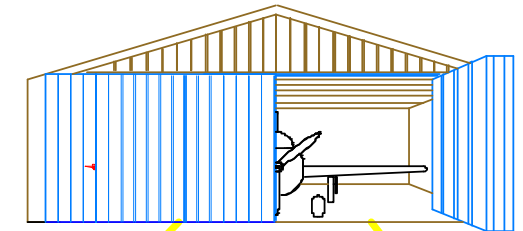
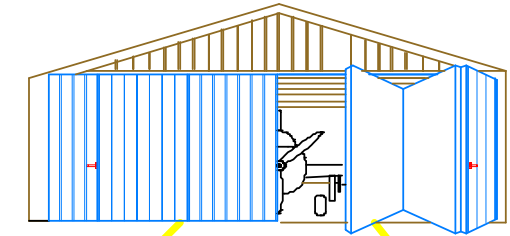



# Cool-Air, Inc. CSA-2.5 AC Accordion Folding Door System

[www.ManualHangarDoors.com](http://www.ManualHangarDoors.com)

Trussed Structure for Rigid Panel Stability with Balanced Weight Support for Easy - Safe Operation

**This unique door is designed to provide balanced operation and strong – wind resistant stability.** By hinging the truss like starter panel on the building column, the Accordion Folding door is stabilized. Absolutely all the building opening height is usable. The accordion stack dimension varies by opening width and height and only nine inches is needed to store this 40' x 12' open door on each side. The top mounted guide track requires Five and three quarter inches above the opening offering the prospect of a very low profile building design. No need to have two or three more feet of building height as necessary for the vertical bi-fold doors, reducing your cost in building design as well as providing an economical door.

US Patent Number 6,705,377

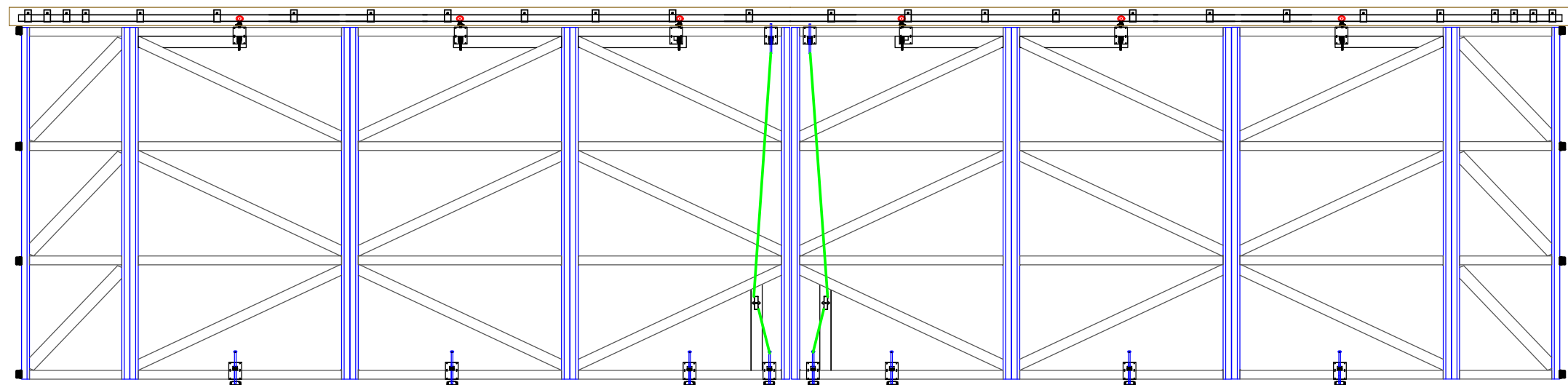

**The Accordion Door Panel** width, inset dimension, quantity of panels and load on the trolley each are evaluated to give the most economical door yet meet strength requirements. There is flexibility in this to either increase or decrease the number of panels for specific needs such as a reduction in the inset dimension.

**The Outboard Brace panel** is designed to stabilize the open door. Standard keyed access to the building is located at the Center Panels which also initiate opening of the full door. If there is no other access or if additional access is needed, one or both outboard brace panels can be installed to operate as a walk door separate from the main door sections. The door can be operated from inside.

**The Door is installed on the face** of almost any type of construction. The door is fitted to the opening so retrofitting existing building is easy and new construction does not require additional height to get the opening needed. The door load is supported by the overhead track with the starter panel hinged to the building column for stability. Wind load is transferred through centered trolleys and centered bottom pins into floor mounted strikes. An optional bottom mounted recessed guide is available. Top and bottom seals are provided and vertical joints are virtually self-sealing. Center Astragal supplied.

## Typical 40' x 12' Door Frame Shown

## More Panels - Narrow Width for Safe Balanced Operation

**CSA-2.5 Complex Structural Aluminum** vertical rail components and bottom rail extruded from 6063-T3 material. Pre-painted white and will not rust or require maintenance. Unique shapes fit together easily, have a self trimming "J" trim feature and provides the ability to assemble easily in the field using TEK screws. CSA-4.5 Components offered for high loads.



**Roll-Formed 20 Gauge Galvanized Steel box tube girt** snugly fits into the aluminum vertical to create the door structure and provide the solid base needed for the exterior sheeting attachment. Also used for the diagonal Brace in the hinged starter panel for truss like strength and allows virtually any sheeting options.

**Floor Mounted Foot Bolt Strike System** Makes locking the door to the floor automatic. Just push the door closed and the geometry of the door movement allows the foot bolt located directly under the trolley to slide into the strike without being raised. This provides for a simplified automatic locking system. Then the starter panel foot bolt attached to the keyed lock drops into the track slot to secure the door closed. A recessed bottom guide track is optional for new construction where weather permits.

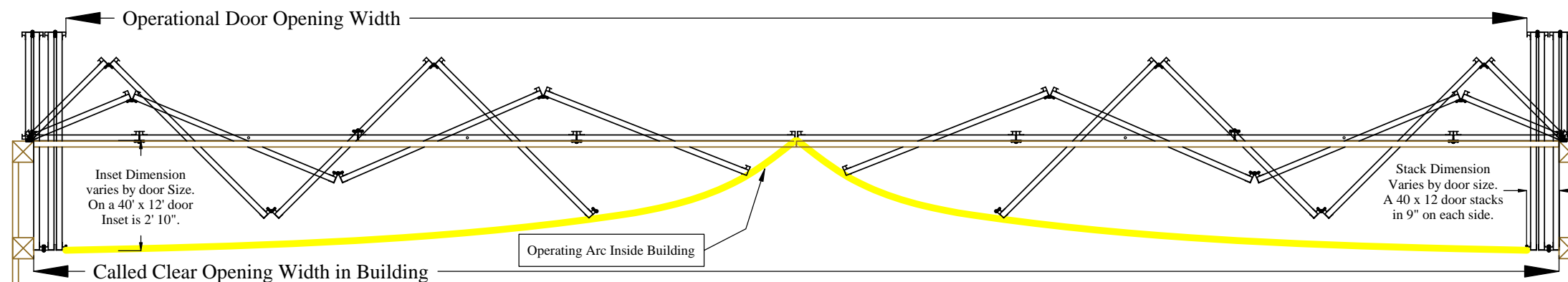

Inset Dimension varies by door size. On a 40' x 12' door Inset is 2' 10".

Stack Dimension Varies by door size. A 40 x 12 door stacks in 9" on each side.

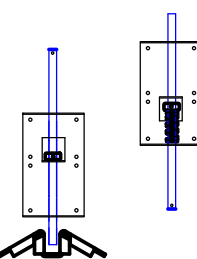
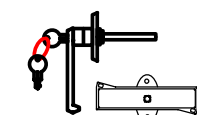

**Keyed Exterior Lock** operates both the Heavy duty Spring Head Bolt and Stainless Steel Foot Bolt for building access through the Hinged Starter Panel. A stranded wire cable connects the head bolt through the inside lock to the foot bolt. Standard operation of the Starter panel causes the large door to open. This can be opened from the inside mounted handle as well. Standard Overhead Door industry Lock is used.

**Extruded Aluminum Astragal** attaches at the center of the door to allow operating room between the door halves and seal that space when the door is closed.

Top and bottom seals are also supplied.

**Stainless Steel 2.5" x 2.5" Butt Hinges** are pre-punched with slotted holes to allow adjustment. The Special Outboard vertical has a weather strip groove and vinyl weather strip is supplied. The hinges are installed with heavy duty lock head TEK screws. Optional Adhesive back foam seals are available to close off the joint between the standard verticals.



**The Standard opening sequence** is shown from overhead with the outboard brace panel opening out. This will have the top track mounted on the outside of the header and will require a track rain cover. Optionally the door can be installed with the outboard brace panel opening in-ward with the track attached to the rear of the header. The components are the same for either installation but an additional track board is required for in-ward swing.

**Standard panel** size, panel quantity and total stack dimension is listed in the below chart. There is flexibility in the door design and changes necessary to meet specific site dimensions or preferences will be accommodated.

Size	10' CSA-2.5			12' CSA-2.5			14' CSA-4.5			16' CSA-4.5		
	Panel Qty	Panel Width	Stack Width	Panel Qty	Panel Width	Stack Width	Panel Qty	Panel Width	Stack Width	Panel Qty	Panel Width	Stack Width
32 Wide	6	6.4'	12"	8	4.6'	18"	6	6.4'	20"	6	6.5'	20"
36 Wide	8	5.2'	18"	8	5.2'	18"	8	5.2'	30"	8	5.2'	30"
40 Wide	8	5.8'	18"	8	5.7'	18"	8	5.7'	30"	8	5.8'	30"
44 Wide	8	6.3'	18"	10	4.9'	24"	8	6.3'	30"	8	6.3'	30"
48 Wide	8	6.9'	18"	10	5.4'	24"	8	6.9'	30"	8	6.9'	30"
52 Wide	10	5.8'	24"	10	5.8'	24"	10	5.8'	40"	10	5.8'	40"
56 Wide	10	6.2'	24"	12	5.1'	30"	10	6.2'	40"	10	6.2'	40"
60 Wide	10	6.7'	24"	12	5.5'	30"	12	5.5'	50"	12	5.5'	50"

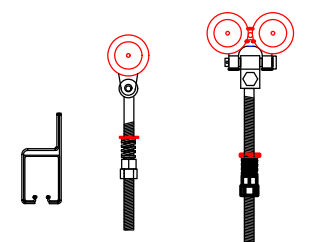

**Door Support and Smooth Operation are provided by the overhead Track System.** This is one time that Box Track is necessary. As the door accords to the side of the opening, the size of the trolley becomes critical. The design of the box track trolley allows a single truck trolley with a load capacity capable of carrying the door load and will allow the tightest stack possible. With larger door sizes, a double truck trolley becomes necessary and this requires the use of a thicker door panel and an increase in the stack dimension. A Thrust Bearing lets the trolley pendant rotate in the door and a Compression spring keeps tension on each trolley so multiple panels can slide and accordion without binding in the track for single person operation. The 16 gauge straight track is supported 24" on center with side mount brackets and 6" on center to support the open stack.